

User manual

DC EV Charger

PEVC3108E



 Zhuhai Sino Energy Technology Co.,Ltd.

 Address: Building 10, No. 81, Dingye Road, High-tech Zone, Zhuhai City

 Postal Code: 519085

 Website: www.sinoevse.com

 Official Email: info.sino@pmac.com.cn

 Service Hotline: +86 15361531855



Version: V1.02

Safety and Compliance

Save these instructions. Read the manual before installation or usage of device.

- 1) Do not put tools, material or body parts into the electric vehicle connector.
- 2) Do not use the DC EV charger if the cabinet, power cord or charging cable are frayed, have broken insulation or show any other signs of damage.
- 3) Do not install or use the DC EV charger if the enclosure is broken, cracked, opened or shows any other indications of damage.
- 4) The DC EV charger should be installed only by a qualified technician.
- 5) Make sure that the materials used and the installation procedures follow local building codes and safety standards.
- 6) The information provided in this manual in no way exempts the user of responsibility to follow all applicable codes or safety standards.
- 7) The manufacturer is not responsible for physical injury, damage to property or damage to equipment caused by the installation of this device.
- 8) This document provides instructions for the DC EV charger and should not be used for any other product. Before installation or use of this product, you should review this manual carefully and consult with a licensed contractor, licensed electrician or trained installation expert to make sure of compliance with local building codes and safety standards.

Warning



Hazardous voltage that gives risk of electrocution



General risk



PE

The input and output voltages of this device are high voltage, which threaten human life safety. Please strictly observe all warnings on the device and user manual. Unauthorized and non-professional service personnel are forbidden to remove the cover of this device.

CONTENT

1 Product Introduction

| | |
|--------------------------------------|----|
| 1.1 Product Description | 01 |
| 1.2 Product Characteristic | 02 |
| 1.3 Product Technical Specifications | 03 |
| 1.4 External Structure | 04 |
| 1.5 Package Contents | 05 |

2 Installation Instruction

| | |
|------------------------------|----|
| 2.1 Installation Preparation | 06 |
| 2.2 Mounting Process | 07 |

3 Configuration and Operation

| | |
|---|----|
| 3.1 Power-on Checking | 11 |
| 3.2 Start and stop charging by your charge card | 11 |

4 Indication and Fault

| | |
|--|----|
| 4.1 Indicator Status | 14 |
| 4.2 Fault Code and Resolution(LCD display) | 15 |

5 Warranty and Service

| | |
|----------------------|----|
| 5.1 Customer Service | 16 |
| 5.2 After Service | 16 |
| 5.3 Contact Us | 16 |

1 Product Introduction

1.1 Product Description

The DC EV charger is the top choice for powering battery electric vehicles (BEV) and plug-in electric vehicles (PHEV) today. It is designed for quick charging in both public and private locations, such as retail and commercial parking spaces, fleet charging stations, highway rest areas, workplaces, residences, etc.

The DC EV charger has the advantage of easy installation. The ground-mounted design and pluggable power modules allow for flexible installation. The DC EV charger also features network communication capability; It is able to connect with remote network systems and provide drivers of electric cars real-time information, such as the locations of charging stations, charging progress information and billing information. The DC EV charger has a friendly user interface with HMI, a power supply safety system and excellent waterproof and dustproof technology to provide the best choice for outdoor environments.

1.2 Product Characteristic



7 Inch LCD Display

Straightforward user interface with 7 inch panel, which display the real-time charging status, including time, voltage, current, power and temperature.

Convenient operation

Easy installation with modular design, adapt to indoor and outdoor environment. Ingress protection up to IP54.

Simultaneous charging output

Applicable to dual output and multiple output model, smart Charging model to adjust the power loading, Load sharing to ensure the best utilization.

High intelligence

Powerful information collection, transmission and communication functions, compatible to OCPP backend office, support user authentication options.

Easy to install and use

The installation process is simple, payment is convenient and fast, supports mobile application software or IC card swiping. Fully compatible with all EV in the market.

1.3 Product Technical Specifications

| Parameter type | Description | PEVC3108E |
|----------------------|-----------------------------|---|
| Input | Power Supply | 3P+N+PE |
| | Rated voltage | 400VAC±10% |
| | Frequency | 50/60Hz |
| | THDi | ≤5% |
| | Efficiency | ≥95% |
| | Power Factor | ≥0.98 |
| Output | Connector Type | CCS2/JAP |
| | Voltage | 150-1000VDC |
| | DC Current | 200A max |
| | Power Rating | 60kW~240kW |
| | Voltage Accuracy | ≤0.5% |
| | Current Accuracy | ≤±1% |
| General | HMI | 7-Inch Touchscreen |
| | Payment Method | RFID Card,APP |
| | Cable Length | 5m |
| | Communication Protocol | OCPP 1.6J |
| | Operating Noise Level | ≤60dB |
| | Ingress Rating | IP54 |
| | IK Rating | IK10 |
| | Power Meter | Accuracy Class 1.0 energy meter |
| | Enclosure | Galvanized steel, surface sprayed with anti-corrosion paint |
| | Place of Installation | Indoor / Outdoor |
| | Product Dimension(W*D*H) | 750*750*1900mm |
| | Package Dimension(W*D*H) | 1000*920*2050mm |
| Environmental | Protection | Over Current, Under Voltage, Over Voltage, Short Circuit, Residual Current, Surge Protection, Over Temperature, Ground Protection |
| | Certification Standard | EN/IEC 61851-1, EN/IEC 61851-23, EN/IEC 61851-24, IEC 62196-1, IEC 62196-3 |
| | Operating temperature | -30°C~+50°C |
| | Storage temperature | -40°C~+75°C |
| | Maximum Installation Height | ≤2000m |
| | Operating Humidity | 5%~95% RH |

1.4 External Structure

Dimension drawing

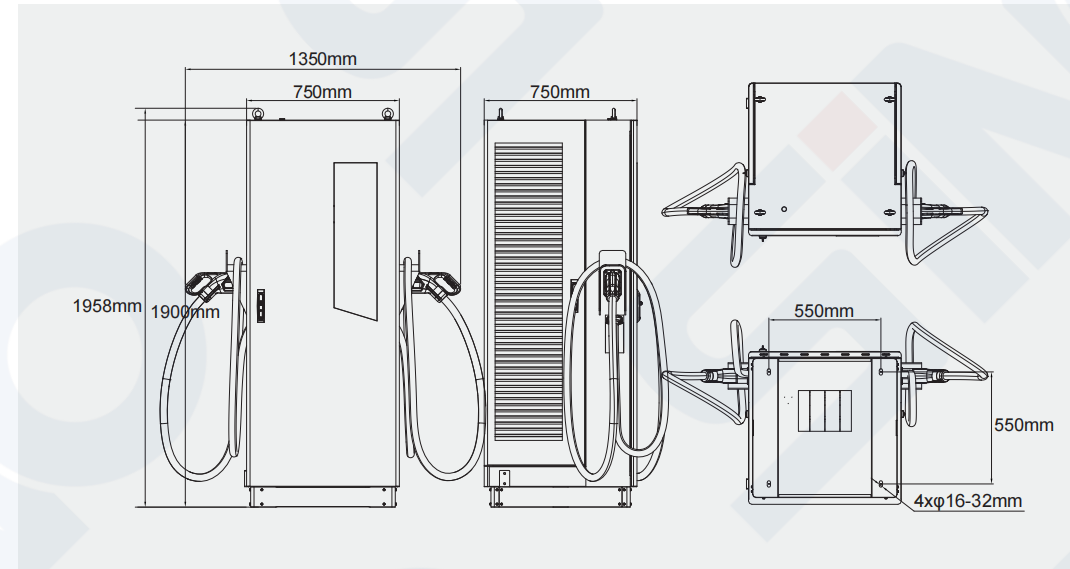





External view

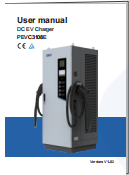

1.5 Package Contents

Unpack the product. Please check and verify following items after receiving the charger:

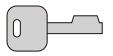
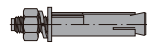



- 1) Visual inspection on charger's external appearance. If there is any breakage or other damage, please notify the seller immediately.
- 2) Check type and quantity of all accessories as follows. If there is a shortage in the quantity of any items or if any items are missing, please contact the seller at once.

| General parts | | |
|---|---|---|
|  |  |  |
| User manual (x1) | RFID card (x2) | Certificate (x1) |
|  |  |  |
| Key (x3) | Expansion bolt M12×100 (x4) | Emergency button protection(x1) |

2 Installation Instruction

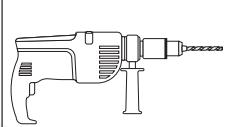
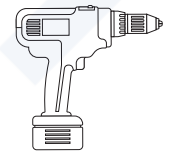
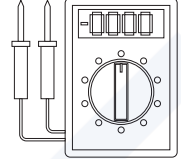
2.1 Installation Preparation

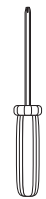
Please prepare the following tools before installation:

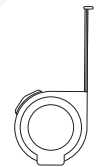
| | | | |
|---|---|---|---|
|  |  |  |  |
| Hammer drill and drill bit(φ 22mm,7/8 inch) | Electric drill | Multimeter | Hammer |
|  |  |  |  |
| Phillips screwdriver M4(length)<100mm | Adjustable wrench | Diagonal Pliers | Measuring tape (5m) |

⚠ Installation Notice

- Electrical devices should only be installed, operated, and maintained by qualified technician. No responsibility is assumed by the manufacturer for any consequences arising out of the use of this device.
- When installing wires, do not turn on the power supply.
- The length of the power cable and communication cable should be properly reserved to facilitate installation and connection.
- Pay attention to protect the charger enclosure during installation to prevent bumping, scratching the surface, etc.
- The charger must be installed vertically, and the deviation of any direction from the vertical position should not exceed 5°.

2.2 Mounting Process

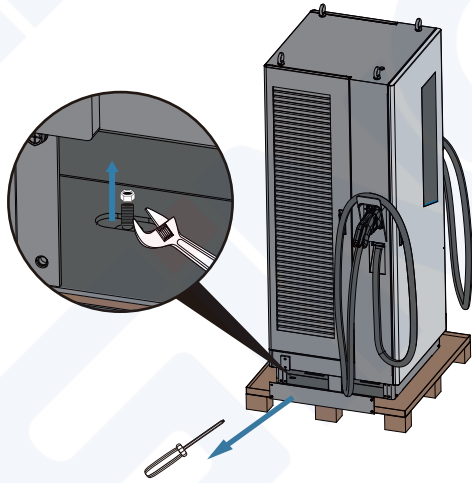

1) Remove the base cover, expose the wooden bracket fixing screw and remove it to separate the charging stake from the wooden bracket.

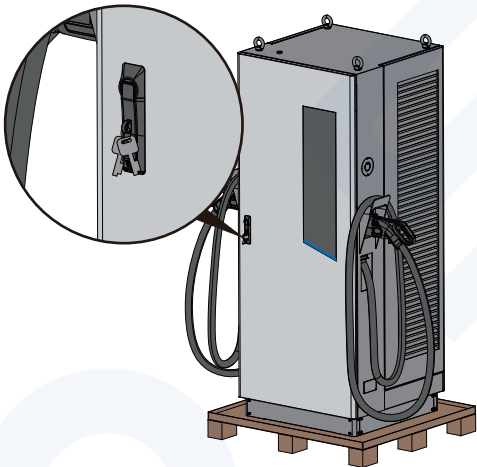

2) Take the key and open the front door to remove the accessory bag.

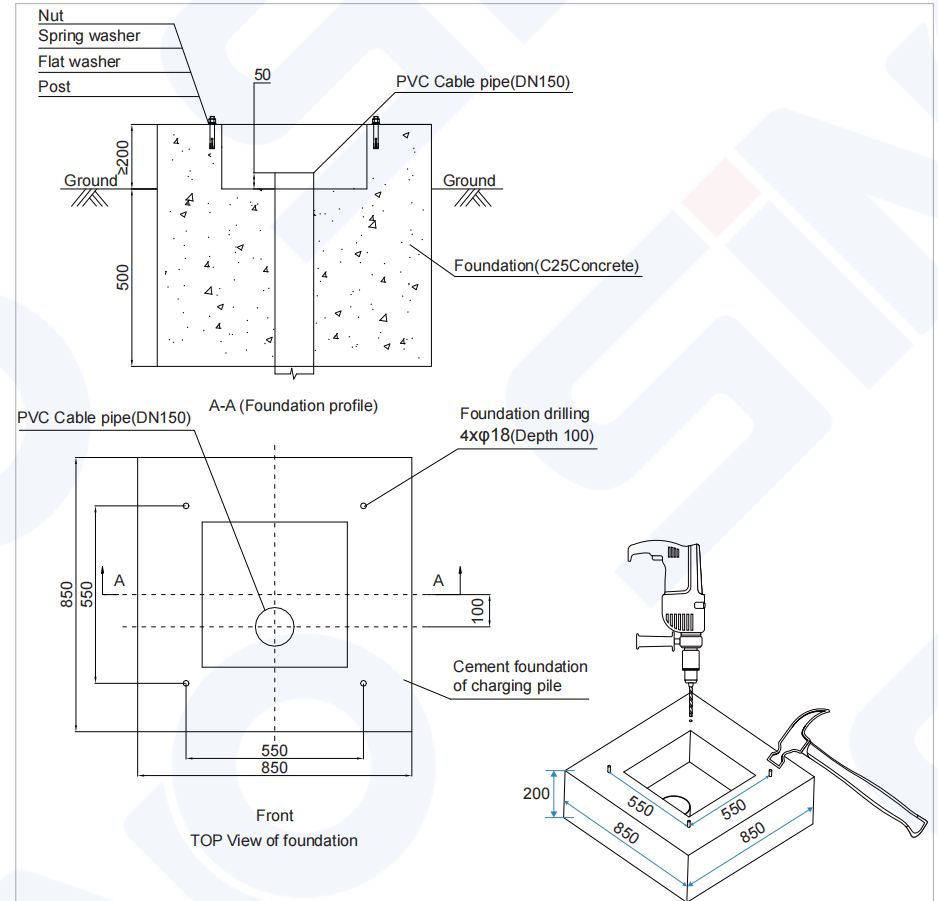

3) Foundation fabrication requirements: the ground height of the foundation is $\geq 200\text{mm}$, the underground depth is 500mm , the length is 850mm , the width is 850mm , four M12 holes with a depth of 100mm are drilled at the designated position of the cement base, and expansion screws are installed at the holes. The embedded conduit shall be $50\sim 80\text{mm}$ higher than the foundation, and the conduit shall be replaced during foundation pouring.

Installation distance requirements: The distance between the upper part of the charging stake and the obstacle is not less than 150mm , the distance between the two sides of the charging stake and the obstacle is not less than 800mm , the distance between the back side and the obstacle is not less than 50mm , and the distance between the front obstacle should ensure that the front door is opened smoothly and maintained internally. When there is a parking line, the horizontal distance between the parking line and the stake should not be less than 400mm .

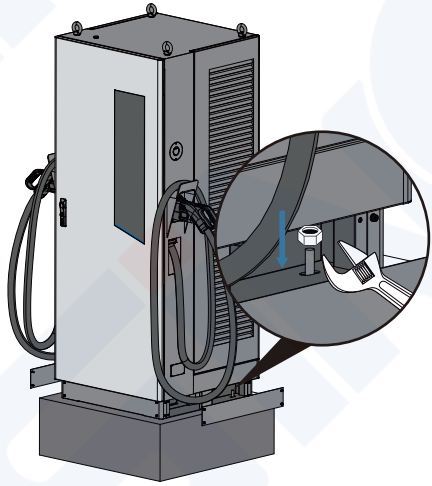

4) Use a crane or forklift to transport the charging stake to the mounting position and align the four corner reserved screw posts. Use a wrench to tighten the four corner nuts to secure the charging stake to the base.

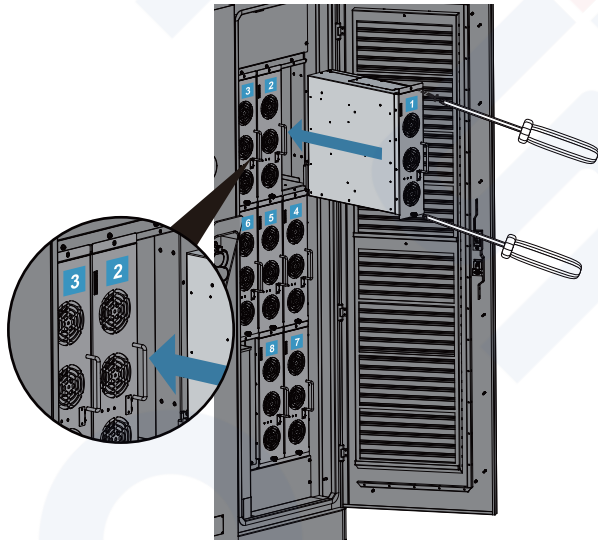

5) Open the right door, insert the module into the corresponding numbered module slot, and tighten the upper and lower screws.

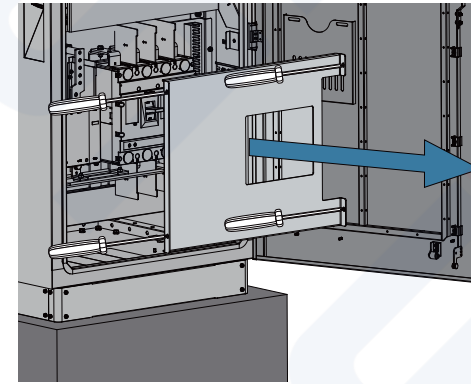

6) Open the front door and release the input PC shield with a screwdriver.

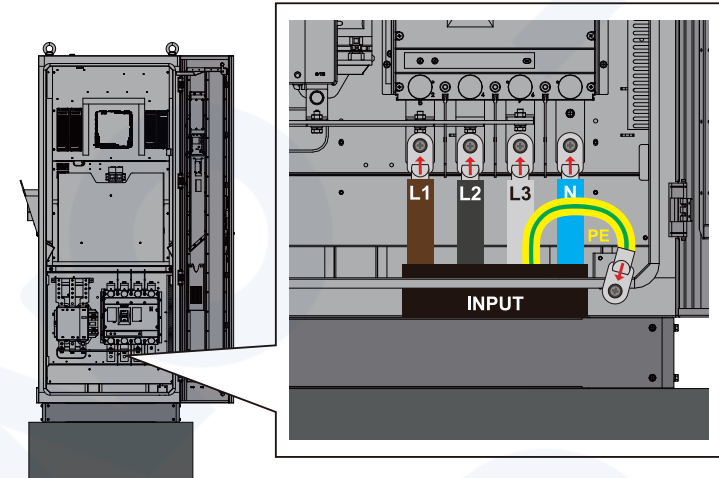

| Model | Recommended cable | Stripping Length | Screw | Recommended Torque |
|-------|---|------------------|-------|--------------------|
| 60kW | L1/L2/L3/N:50mm ² ;PE:25mm ² | 250mm | M8 | 10N·m |
| 120kW | L1/L2/L3/N:120mm ² ;PE:70mm ² | 250mm | M8 | 10N·m |
| 180kW | L1/L2/L3/N:185mm ² ;PE95mm ² | 250mm | M10 | 20N·m |
| 240kW | L1/L2/L3/N:300mm ² ;PE150mm ² | 250mm | M12 | 36N·m |

7) Connect the power cord L1/L2/L3/N/PE according to the legend. Load back the PC shield and close the front door after wiring is completed.

3 Configuration and Operation

3.1 Power-on Checking

Please check / re-check the following items prior to initial Power-on:

- 1) The location of the charger should be convenient for operation and maintenance.
- 2) Before installation of the charger, ensure that the AC input component in the power supply is properly installed with the required protection.
- 3) Double confirm the charger is installed properly.
- 4) No components or other items have been left inside of the charger.

3.2 Start and stop charging by your charge card

Operation

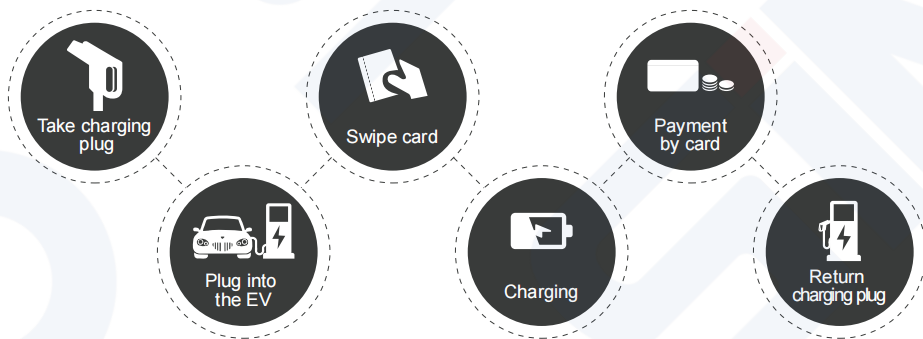

1) Choose a compatible plug.



2) Connect the plug to the EV.

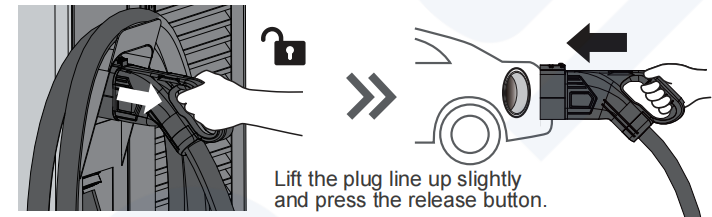

3) Swipe the authorized RFID card to start charging. The authorized RFID can be used directly without any activation or setting.



4) Once charging commences, status information is displayed on the screen. The following illustrations demonstrate the start to near complete charging procedure.

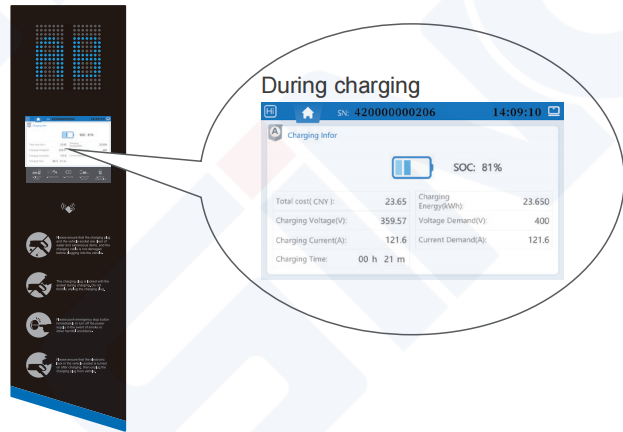

6) Return the plug to the holder.

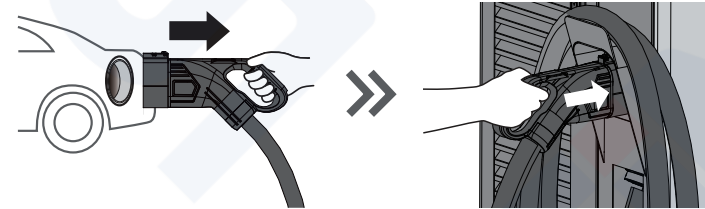

5) Swipe the authorized RFID card to stop.



4 Indication and Fault

4.1 Indicator Status

| | LED Light Status | Description of Charging status |
|----|--------------------|--|
| AB | Green light on | The Charger is power on. |
| AB | Blue light blink | The charger is ready. |
| AB | Blue light raising | The charger is working for EV. |
| AB | Red light on | Failure or alarm status, unable to charge. |

4.2 Fault Code and Resolution(LCD display)

| Fault Status | Troubleshooting suggestion |
|--------------------------------|---|
| Card Detector | Check whether the connecting cable of the card reader is loose. |
| SPD | Check whether the SPD is abnormal. |
| Emergency | Reset emergency stop button. |
| Over voltage of Power Supply | Check whether the input voltage of the equipment is too high. |
| Under voltage of Power Supply | Check whether the input voltage of the equipment is too low. |
| Circuit breaker Status | Check whether the circuit breaker is opened. |
| Over temperature | Stop using for a period of time and wait for the equipment to return to the normal temperature range and restart. |
| Communication of Charge Module | Communication with the AC/DC module is broken. |
| Cabinet Door | The equipment access door is opened. |
| Storage state | Please contact professional after-sales personnel to deal with it. |
| Control System | Please contact professional after-sales personnel to deal with it. |

5 Warranty and Service

5.1 Customer Service

We can provide customers with professional product advice and purchase options. All emails will be responded within 48 hours during working days. We provide online customer service in multiple languages. You can communicate with ease, or contact us through email anytime.

5.2 After Service

Please refer to the contract for the warranty period. The specific after-sale plan will be free for replacement or charging a certain maintenance cost according to the specific situations. During the warranty period, customers can apply for replacement or free maintenance for the fault damage caused by product quality. For the fault damage caused by other reasons (human factors, natural factors, etc.), we will provide paid maintenance services.

5.3 Contact Us

SINO is a subsidiary of Zhuhai Pilot Technology Co.,Ltd.If you need to report for repair or inquire about charging product service, please call the company's customer service hotline +86 15361531855 or through the official email info.sino@pmac.com.cn contact us.