



User manual

DC EV Charger

PEVC3106E



 Zhuhai Sino Energy Technology Co.,Ltd.

 Address: Building 10, No. 81, Dingye Road, High-tech Zone, Zhuhai City

 Postal Code: 519085

 Website: www.sinoevse.com

 Official Email: info.sino@pmac.com.cn

 Service Hotline: +86 15361531855



Version: V1.01

Safety and Compliance

Save these instructions. Read the manual before installation or usage of device.

- 1) Do not put tools, material or other parts into the electric vehicle connector.
- 2) Do not use the DC EV charger if the cabinet, power cord or charging cable are frayed, have broken insulation or show any other signs of damage.
- 3) Do not install or use the DC EV charger if the enclosure is broken, cracked, opened or shows any other indications of damage.
- 4) The DC EV charger should be installed only by a qualified technician.
- 5) Make sure that the materials used and the installation procedures follow local building codes and safety standards.
- 6) The information provided in this manual in no way exempts the user of responsibility to follow all applicable codes or safety standards.
- 7) The manufacturer is not responsible for physical injury, damage to property or damage to equipment caused by the installation of this device.
- 8) This document provides instructions for the DC EV charger and should not be used for any other product. Before installation or use of this product, you should review this manual carefully and consult with a licensed contractor, licensed electrician or trained installation expert to make sure of compliance with local building codes and safety standards.

Warning



Hazardous voltage that gives risk of electrocution



General risk



PE

The input and output voltages of this device are high voltage, which threaten human life safety. Please strictly observe all warnings on the device and user manual. Unauthorized and non-professional service personnel are forbidden to remove the cover of this device.

CONTENT

1 Product Introduction

1.1 Product Description	01
1.2 Product Characteristic	02
1.3 Product Technical Specifications	03
1.4 External Structure	04
1.5 Package Contents	05

2 Installation Instruction

2.1 Installation Preparation	06
2.2 Mounting Process	07

3 Configuration and Operation

3.1 Power-on Checking	11
3.2 Start and stop charging by your charge card	11

4 Indication and Fault

4.1 Indicator Status	14
4.2 Fault Code and Resolution(LCD display)	15

5 Warranty and Service

5.1 Customer Service	16
5.2 After Service	16
5.3 Contact Us	16

1 Product Introduction

1.1 Product Description

The DC EV charger is the top choice for powering battery electric vehicles (BEV) and plug-in electric vehicles (PHEV) today. It is designed for quick charging in both public and private locations, such as retail and commercial parking spaces, fleet charging stations, highway rest areas, workplaces, residences, etc.

The DC EV charger has the advantage of easy installation. The ground-mounted design and pluggable power modules allow for flexible installation. The DC EV charger also features network communication capability; It is able to connect with remote network systems and provide drivers of electric cars real-time information, such as the locations of charging stations, charging progress information and billing information. The DC EV charger has a friendly user interface with HMI, a power supply safety system and excellent waterproof and dustproof technology to provide the best choice for outdoor environments.

1.2 Product Characteristic



7 Inch LCD Display

Straightforward user interface with 7 inch panel, which display the real-time charging status, including time, voltage, current, power and temperature.

Convenient operation

Easy installation with modular design, adapt to indoor and outdoor environment. Ingress protection up to IP54.

Simultaneous charging output

Applicable to dual output and multiple output model, smart Charging model to adjust the power loading, Load sharing to ensure the best utilization.

High intelligence

Powerful information collection, transmission and communication functions, compatible to OCPP backend office, support user authentication options.

Easy to install and use

The installation process is simple, payment is convenient and fast, supports mobile application software or IC card swiping. Fully compatible with all EV in the market.

1.3 Product Technical Specifications

Parameter type	Description	PEVC3106E -60K1000D2	
Input	Power Supply	3P+N+PE	
	Rated voltage	400VAC±10% 480VAC±10%	
	Frequency	50/60Hz	
	THDi	≤5%	
	Efficiency	≥95%	
	Power Factor	≥0.98	
Output	Connector Type	CCS1/CCS2	
	Voltage	150-1000VDC	
	DC Current	200A max	
	Power Rating	60kW	
	Voltage Accuracy	≤0.5%	
General	Current Accuracy	≤±1%	
	HMI	7-Inch Touchscreen	
	Payment Method	RFID Card,APP	
	Cable Length	5m	
	Communication Protocol	OCPP 1.6J	
	Operating Noise Level	≤75dB	
	Ingress Rating	IP54	
	IK Rating	IK10	
	Power Meter	Accuracy Class 1.0 energy meter	
	Enclosure	Galvanized steel, surface sprayed with anti-corrosion paint	
	Place of Installation	Indoor / Outdoor	
	Product Dimension(W*D*H)	700*240*1750mm	
	Package Dimension(W*D*H)	1100*750*1890mm	
	Protection		Over Current,Under Voltage, Over Voltage,Short Circuit, Surge Protection,Over Temperature, Ground Protection
		Residual Current	/
	Certification Standard		EN/IEC 61851-1, EN/IEC 61851-23, EN/IEC61851-24, IEC 62196-1,IEC 62196-3
Environmental	Operating temperature	-30°C~+50°C	
	Storage temperature	-40°C~+75°C	
	Maximum Installation Height	≤2000m	
	Operating Humidity	5%~95% RH	

1.4 External Structure

Dimension drawing

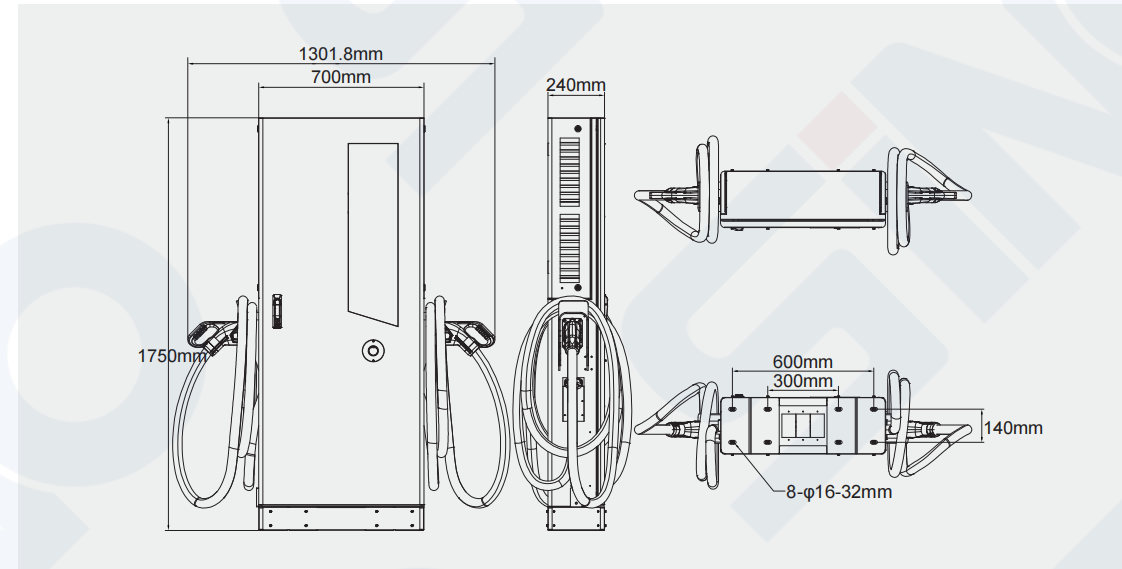





External view

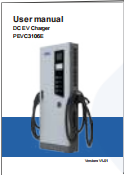

1.5 Package Contents

Unpack the product. Please check and verify following items after receiving the charger:

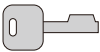
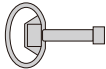



- 1) Visual inspection on charger's external appearance. If there is any breakage or other damage, please notify the seller immediately.
- 2) Check type and quantity of all accessories as follows. If there is a shortage in the quantity of any items or if any items are missing, please contact the seller at once.

General parts		
		
User manual (x1)	RFID card (x2)	Certificate (x1)
		
Front door key (x2)	Side door key (x4)	Expansion bolt M12×100 (x8)
		
Emergency button protection(x1)		

2 Installation Instruction

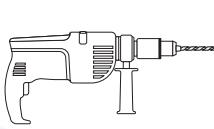
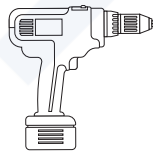
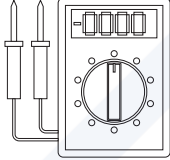
2.1 Installation Preparation

Please prepare the following tools before installation:

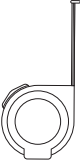
			
Hammer drill and drill bit	Electric drill	Multimeter	Hammer
			
Phillips screwdriver	Adjustable wrench	Diagonal Pliers	Measuring tape (5m)

⚠ Installation Notice

- Electrical devices should only be installed, operated, and maintained by qualified technician. No responsibility is assumed by the manufacturer for any consequences arising out of the use of this device.
- When installing wires, do not turn on the power supply.
- The length of the power cable and communication cable should be properly reserved to facilitate installation and connection.
- Pay attention to protect the charger enclosure during installation to prevent bumping, scratching the surface, etc.
- The charger must be installed vertically, and the deviation of any direction from the vertical position should not exceed 5°.

2.2 Mounting Process

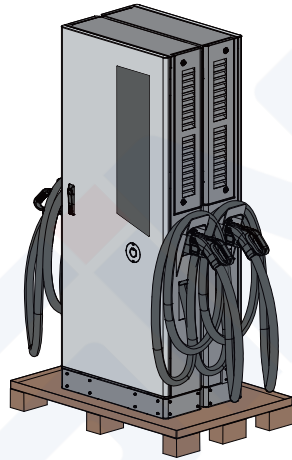

1) Unpack the wooden box.

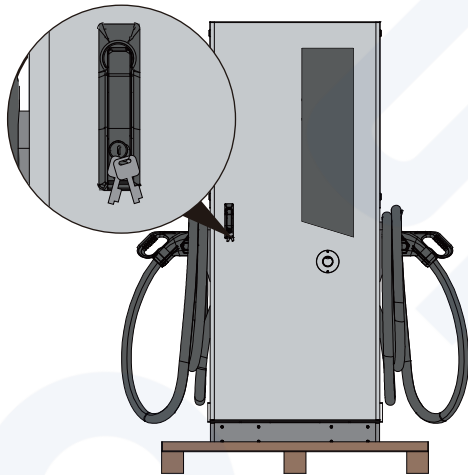

2) Take the key and open the front door to remove the accessory bag.

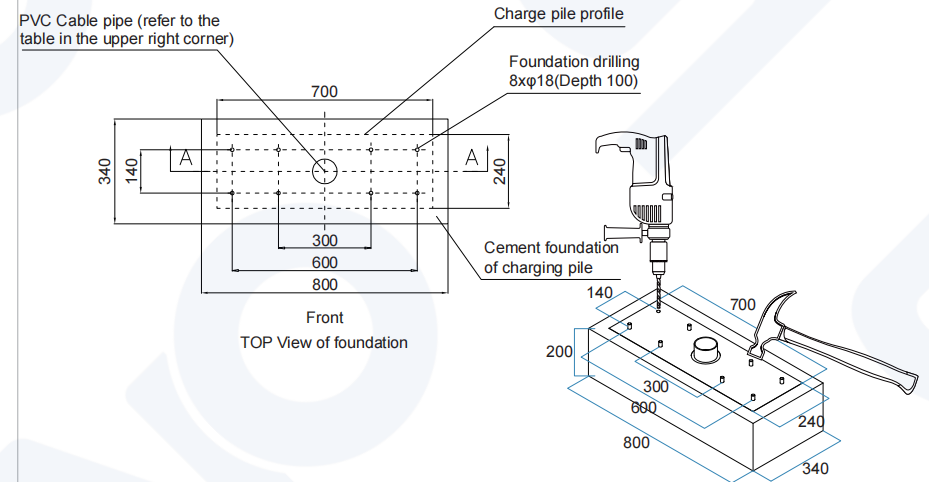
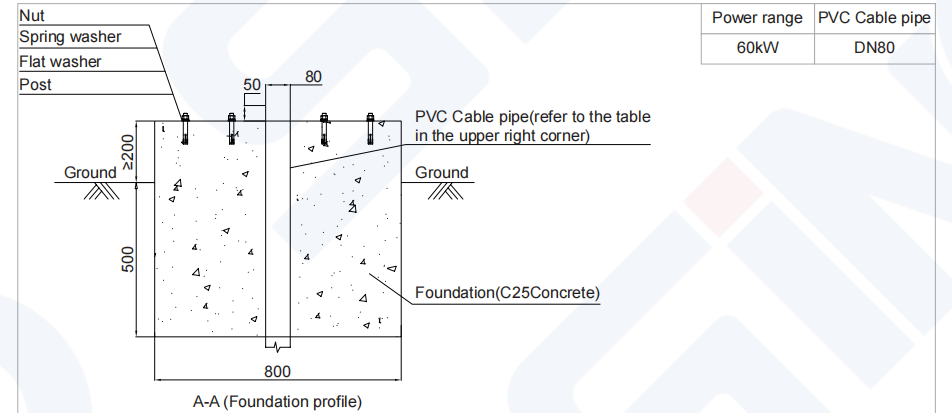

3) Foundation fabrication requirements: the ground height of the foundation is ≥ 200 mm, the underground depth is 500mm, the length is 700mm, the width is 340mm, eight M12 holes with a depth of 100mm are drilled at the designated position of the cement base, and expansion screws are installed at the holes. The embedded conduit shall be 50~80mm higher than the foundation, and the conduit shall be replaced during foundation pouring.

Installation distance requirements: The distance between the upper part of the charging stake and the obstacle is not less than 150mm, the distance between the two sides of the charging stake and the obstacle is not less than 800mm, the distance between the back side and the obstacle is not less than 50mm, and the distance between the front obstacle should ensure that the front door is opened smoothly and maintained internally. When there is a parking line, the horizontal distance between the parking line and the stake should not be less than 400mm.

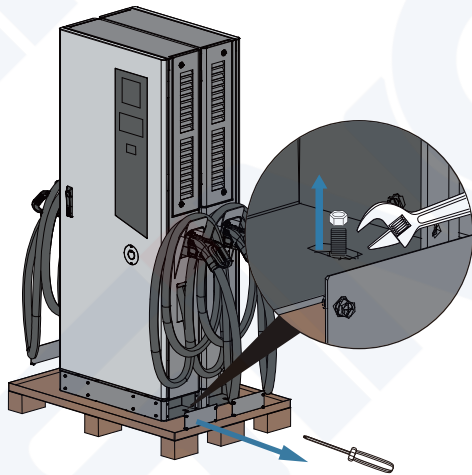

4) Remove the base cover, expose the wooden bracket fixing screw and remove it to separate the charging stake from the wooden bracket. Use a crane to transport the charging stake to the mounting position and align the four corner reserved screw posts. Use a wrench to tighten the four corner nuts to secure the charging stake to the base.

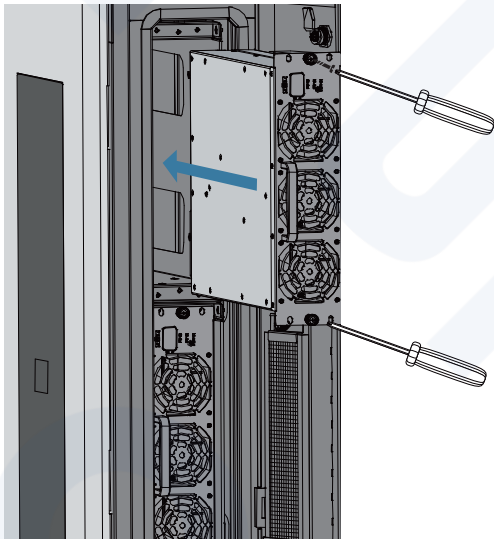

5) Open the right door, insert the module into the corresponding numbered module slot, and tighten the upper and lower screws.

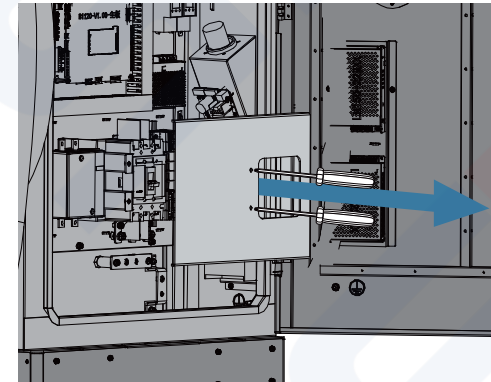

6) Open the front door and release the input PC shield with a screwdriver.

PEVC3106E

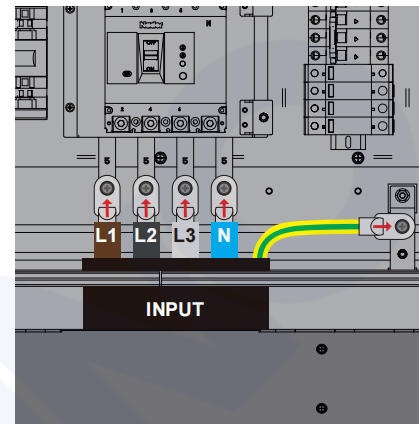

PEVC3106U

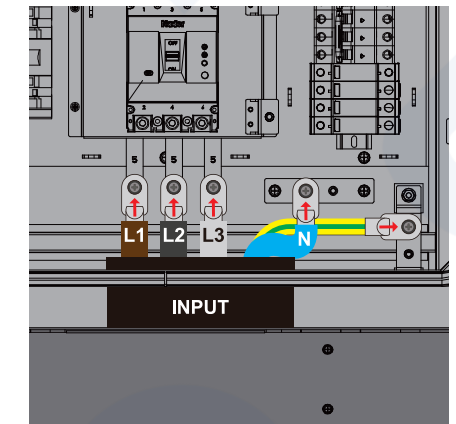

Model	Recommended cable	Stripping Length	Screw	Torque
60kW	L1/L2/L3/N:50mm ² ;PE:25mm ²	250mm	M8	10N·m

7) Connect the power cord L1/L2/L3/N/PE according to the legend. Load back the PC shield and close the front door after wiring is completed.

3 Configuration and Operation

3.1 Power-on Checking

Please check / re-check the following items prior to initial Power-on:

- 1) The location of the charger should be convenient for operation and maintenance.
- 2) Before installation of the charger, ensure that the AC input component in the power supply is properly installed with the required protection.
- 3) Double confirm the charger is installed properly.
- 4) No components or other items have been left inside of the charger.

3.2 Start and stop charging by your charge card

Operation

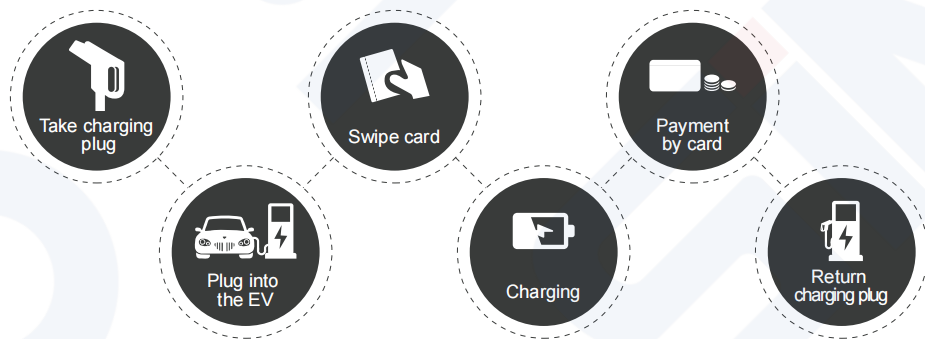

1) Choose a compatible plug (CCS).



2) Connect the plug to the EV.



3) Swipe the authorized RFID card to start charging. The authorized RFID can be used directly without any activation or setting.



4) Once charging commences, status information is displayed on the screen. The following illustrations demonstrate the start to near complete charging procedure.

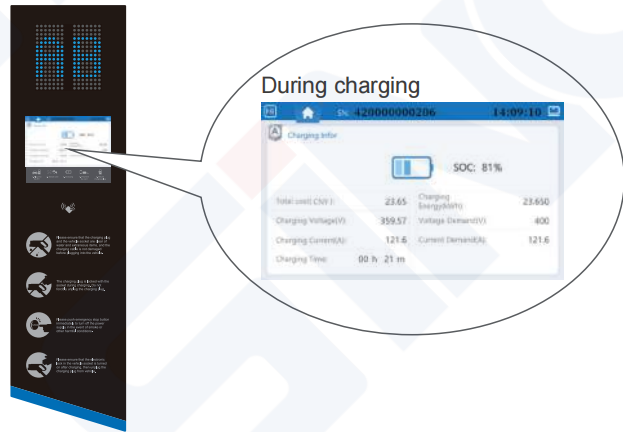

5) Swipe the authorized RFID card to stop.

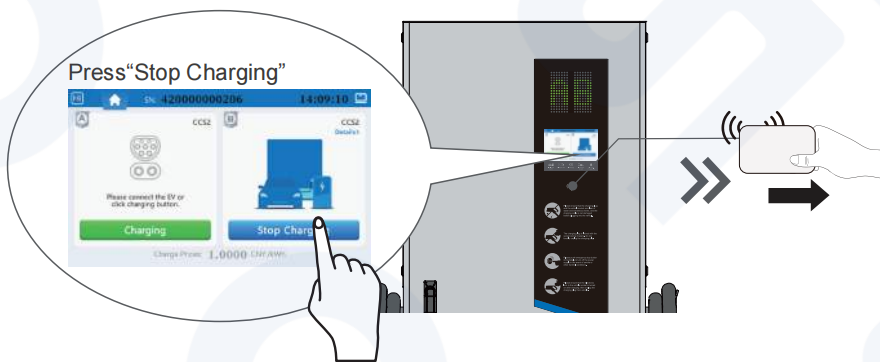

6) Return the plug to the holder.

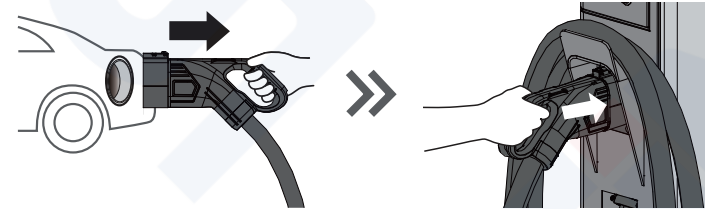

4 Indication and Fault

4.1 Indicator Status

	LED Light Status	Description of Charging status
AB	Green light on	The Charger is power on.
AB	Blue light blink	The charger is ready.
AB	Blue light raising	The charger is working for EV.
AB	Red light on	Failure or alarm status, unable to charge.

